

FLIGHT SYSTEMS, INC
56-5047-00

User's Manual

Table of Contents

2 | Overview and Features
| Unpacking and Inspection

3 | Removal and Installation

4 | Voltage Adjust
| Factory Default

5 | Troubleshooting

6 | Fault Codes

9 | Warranty Information

Back | Repair and Technical Support

Overview and Features

- Exact replacement for Onan® 300-5047 control modules
- Improved circuit design over OEM
- Over-sized heatsink for cooler operation
- Encapsulated in automotive grade urethane and fully repairable
- Contains fault code system for easy troubleshooting
- Advanced detection system checks condition of brushes, slip rings, and rotor while cranking. Generator will be prevented from running if damage is likely.
- Communication port for connection to Flight Systems 327v2 modem. Allows for remote monitoring and remote start, (may not be available upon initial release).

This controller, as with all Flight System built devices, comes with a 2-year warranty and a 30-day return policy upon initial purchase of the product.

Unpacking and Inspection

Be careful when unpacking your new controller so that nothing is damaged. Do not expose your controller to static shock prior to or following installation.

Removal and Installation

The controller is accessible through the front cover panel. The controller connector can be accessed by removing the start/stop switch cover. It is highly recommended to disconnect battery power at the battery/disconnect switch before removing the battery cable nut!

- Remove one nut to disconnect battery cable.
- Remove one 10mm bolt holding the start/stop switch cover. Place cover aside without disconnecting wires.
- Unclip controller wiring harness using a small flat screwdriver, if needed.
- Remove two 10mm bolts holding bottom front of controller housing. The housing will not be removable until the next step.
- Using an 8-inch socket extension, remove one 10mm bolt behind controller housing. You will not be able to see this bolt from the front.
- Remove controller housing through front of generator.
- Remove two 10mm screws holding the controller to the housing.
- Installation is reverse of removal. Make sure wire connector latches properly into control board mating connector. Do not over-tighten the battery cable connection!

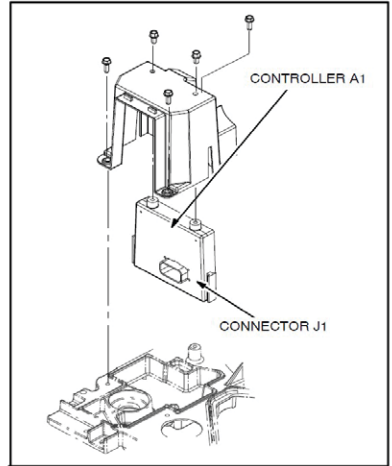

AFTER THREADING INTO A PLASTIC MOUNT ON THE CONTROLLER, IT IS CONSIDERED INSTALLED, VOIDING THE 30-DAY RETURN POLICY!

Voltage Adjust (within 20 seconds after startup)

Due to variations in part tolerances and voltage sensing transformer ratios, a voltage adjustment mode is provided. Under most circumstances, the output voltage should be adjusted to 120v, no load, measured from a circuit breaker (hot) to chassis ground.

- Press start 6 times; the status light will begin blinking to signal that the controller is now in voltage adjust mode.
- Short press the start button to increase voltage by half a volt.
- Long press (more than 2 seconds) the start button to decrease voltage by half a volt.

Wait for the status light to stop flashing. If the generator shuts down before status light stops flashing, the voltage setting will not be saved.

If the generator needs to be shut down during this operation, hold stop for two seconds.

Factory Default

To restore all calibrations to factory default:

- Press the stop button ten times while generator is not running and not in a fault condition. The status indicator will come on solid.
- Hold stop button until status indicator turns off.

Troubleshooting

Blinking while Cranking

Causes: normal operation, no issue.

Solid Light while Cranking

NEW FEATURE

Causes: open field or high resistance, check slip rings and brushes for continuity.

NOTE: Cranking will continue, attempting to clean the slip rings by friction. Fuel is disabled until field resistance returns to safe range.

No Response at Control Switch

Causes: faulty switch, poor connections, missing connections, or dead battery

Starter Engages and Disengages

Causes: low cranking voltage

Starting Batteries Don't Maintain a Charge

Causes: marginal battery, poor battery connections, or faulty charging system

No AC Power While Generator is Running

Causes: a circuit breaker is off, tripped or malfunctioning, or poor AC connections at controller harness or circuit breaker

Engine Surging Without Fault Shutdown

Causes: fuel leaks, restrictions or air bubbles, worn slip rings/brushes, misadjusted or faulty governor, worn generator bearing

Testing the Generator's Windings

This procedure requires an ohmmeter, set on the lowest resistance scale (usually 200-ohm.) On the control board mating connector, with the generator NOT RUNNING, measure these points:

- Pin 3 to Pin 13 - Quadrature winding = 2.0-4.0 ohms.
- Pin 1 to Pin 14 - Field winding (rotor) = 20-30 ohms.
- Pin 33 to Pin 34 - Main Stator winding = .30-.50 ohms.

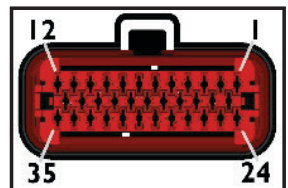

Fault Codes

At fault shutdown, the status indicator light will blink to indicate a fault code. Blinking will continue for 5 minutes and then stop. To restore blinking after timeout, press the control switch to STOP briefly, then press STOP 3 times.

No. 1 – Engine Over Temperature (Diesel Only)

While running, engine coolant temperature was above 239°F/115°C for 10 seconds.

No. 2 – Low Oil Fault

(All Except HGJBB) While running, oil pressure dropped below 14 psi for 3 seconds.

(HGJBB) Oil level switch grounded for 30 seconds; low oil level.

No. 3 – Service Fault

A two-digit second-level fault occurred.

- *Press STOP briefly to activate the two-digit code indication. The two-digit code consists of 1-5 blinks, a brief pause, and then 1-9 blinks. The first set of blinks represents the tens digit and the second set of blinks represents the units digit. For example, shutdown code No. 32 would be: blink-blink-blink-pause-blink-blink-long pause-repeat*

No. 4 – Over Crank

Cranking time exceeded 35 seconds.

Two-digit Service Faults

No. 12 – Over Voltage

After voltage regulation was enabled, output voltage was higher than 150VAC for 75 milliseconds or higher than 138VAC for 3 seconds.

No. 13 – Under Voltage

After voltage regulation was enabled, output voltage was lower than 108VAC for 5 seconds.

No. 14 – Over Frequency

Frequency was higher than 70Hz for 40 milliseconds or higher than 66Hz for 6 seconds.

No. 15 – Under Frequency

Frequency was less than 54Hz for more than 8 seconds.

No. 17 – Fuel Pump Fault

Fuel pump circuit open.

No. 19 – Actuator Shorted or Open (EFI/Diesel Only)

Before cranking, the controller sensed an open or shorted governor actuator or wiring.

No. 22 – Actuator Overload (EFI/Diesel Only)

Due to overloaded AC output or poor engine performance, the controller kept the governor actuator at full-duty cycle for 60 consecutive seconds.

No. 24 – Faulty Engine Temperature Sender (Diesel Only)

After 10 minutes of running, the controller sensed an open temperature sender or wiring.

No. 27 – VAC Sense Lost

While running, the controller lost stator AC sensing voltage even though the field was functioning normally.

No. 29 – High Battery Voltage

Before cranking, the controller sensed that incoming battery voltage was greater than 19.2 volts for 5 milliseconds, or greater than 19.2 volts for 1 second, while running.

No. 31 – Overspeed Fault (Carb/EFI Only)

Engine RPM greater than safe operating speed.

No. 32 – Starting Fault

The controller could not suitably detect cranking speed for 12 seconds. Possible open quadrature winding or broken brushes/dirty slip rings.

No. 33 – Not a valid code

The controller is blinking 3 to indicate a service fault. Follow instructions for No. 3 - Service Fault.

No. 35 – EEPROM Memory Checksum Fault

During power on, the controller detected corrupted EEPROM memory.

No. 36 – Mechanical Fault

While running, engine speed fell to less than 500 RPM for .5 seconds, uncommanded by controller. This code can come up when genset runs out of fuel.

No. 37 – Invalid Set Configuration (Carb/EFI Only)

Ratio of AC Frequency to ignition speed is not correct. Slipping belt or broken engine coupling are the most frequent causes.

No. 38 – Field Overload

While running, field voltage higher than 150VAC for 10 seconds.

No. 41 – Generator Rotor Short

During cranking, the controller sensed that the field circuit/rotor was shorted to ground.

No. 42 – ROM Fault

During power on, the controller detected a ROM error.

No. 43 – RAM Fault

During power on, the controller detected a RAM error.

No. 45 – Speed Sense Lost

The controller lost speed sense for .25 seconds.

No. 47 – Ignition Fault (Carb/EFI Only)

Ignition pulses from a magneto not detected for 1 second.

No. 48 – Loss of Field Sense

While running, the field sense circuit on the controller failed, or field voltage dropped to zero.

No. 51 – Processor Fault

CRC verification failed on power up.

No. 52 – Fuel Injector Fault (EFI Only)

Open or shorted fuel injector.

No. 53 – MAT Sensor Fault (EFI Only)

MAT resistance greater than 300K ohms.

No. 56 – MAP Sensor Fault (EFI Only)

MAP sensor less than 50kPa while cranking.

No. 57 – Over Prime

The local or remote switch was held in the prime/stop position for more than 3 minutes.

No. 58 – Exhaust Gas Temperature Fault (EFI Only)

EGT greater than 1200F for 2 seconds.

No. 81 – Exhaust Gas Temperature Sensor Open (EFI Only)

EGT below 140F for 2 minutes (or after 2 minutes from starting).

No. 82 – Exhaust Gas Temperature Sensor Shorted (EFI Only)

EGT is detected at 1832F for 1 second. Unit will not crank.

Warranty Information

This Flight Systems manufactured replacement controller is warranted to be free from defects in materials and workmanship for a period of two years from the date it was sold.

Flight Systems Limited Warranty covers the repair or replacement of defective products within the warranty period. It does not cover the cost of installation, removal costs incurred, or possible damage to other equipment (including the generator or parts thereof) as a result of this product.

Flight Systems (or its authorized agent) shall reserve the right to determine the cause of malfunction. If we determine that it was due to abuse, misuse, improper installation, acts of nature (such as storm), failure to perform recommended genset maintenance procedures, or problems elsewhere in the genset, the warranty claim shall be dissolved and established standard repair rates apply.

Flight Systems 30-Day Return Policy is only valid for 30 days after initial purchase of any Flight Systems product. Installation of any products will result in termination of the 30-Day Return Policy on that product. Refund/Credit issued shall be less a 25% per item restocking and testing fee as long as the product is in new undamaged condition. Shipping charges are non-refundable.

Repair and Technical Support

If this product suffers a failure when out of warranty it can be rebuilt. Applicable Flight Systems repairs are issued a one-year warranty.

Please fill out and print our Repair Shipping Form located at www.flightsystems.com and include it with any repairs. Repairs can be shipped to:

Flight Systems
207 Hempt Road
Mechanicsburg, PA 17050

Any repairs not sent with proper contact information will be held for no more than 6 months from the date received before being recycled by Flight Systems.

Technical support is also available by phone or email for all Flight Systems products:

Phone: 717-590-7330

Email: techs@flightsystems.com

Open Monday-Friday, 8am-5pm Eastern

